



CCD ANALOG FRONT-END FOR DIGITAL CAMERAS

FEATURES

- **CCD Signal Processing:**
 - **36-MHz Correlated Double Sampling (CDS)**
- **12-Bit Analog-to-Digital Conversion:**
 - **36-MHz Conversion Rate**
 - **No Missing Codes Ensured**
- **78-dB Input-referred SNR (at CDS Gain 0 dB)**
- **Programmable Black Level Clamping**
- **Programmable Gain Amp (PGA):**
 - 9 dB to +35 dB, –3 dB to +9 dB
by Analog Front Gain (CDS)
 - 6 dB to +26 dB by Digital Gain
- **PORTABLE OPERATION:**
 - **Low Voltage: 2.7 V to 3.6 V**
 - **Low Power: 85 mW at 3.0 V and 36 MHz,
1 mW in Standby Mode**
- **QFN-36 Package**

DESCRIPTION

The VSP2582 is a complete mixed-signal processing IC for digital cameras that provides correlated double sampling (CDS) and analog-to-digital conversion (ADC) for the output of charge-coupled device (CCD) array. The CDS extracts video information of the pixels from the CCD signal, and the ADC converts it to a digital signal. For varying illumination conditions, –9 dB to +35 dB very stable gain control is provided. This gain control is linear in dB. Input signal clamping and offset correction of the input CDS are also provided.

Offset correction is performed by an Optical Black (OB) level calibration loop, and held at a calibrated black level clamping for an accurate black level reference. Additionally, the black level is quickly recovered after a gain change.

The VSP2582 is available in a QFN-36 package, and operates from a single +3 V supply.



Please be aware that an important notice concerning availability, standard warranty, and use in critical applications of Texas Instruments semiconductor products and disclaimers thereto appears at the end of this data sheet.

All trademarks are the property of their respective owners.



This integrated circuit can be damaged by ESD. Texas Instruments recommends that all integrated circuits be handled with appropriate precautions. Failure to observe proper handling and installation procedures can cause damage.

ESD damage can range from subtle performance degradation to complete device failure. Precision integrated circuits may be more susceptible to damage because very small parametric changes could cause the device not to meet its published specifications.

PACKAGE/ORDERING INFORMATION⁽¹⁾

PRODUCT	PACKAGE-LEAD	PACKAGE DESIGNATOR	SPECIFIED TEMPERATURE RANGE	PACKAGE MARKING	ORDERING NUMBER	TRANSPORT MEDIA, QUANTITY
VSP2582RHN	QFN-36	RHN	–25°C to +85°C	VSP2582	VSP2582RHN	Tray
					VSP2582RHNR	Tape and Reel

(1) For the most current package and ordering information see the Package Option Addendum at the end of this document, or see the TI web site at www.ti.com.

ABSOLUTE MAXIMUM RATINGS⁽¹⁾

Over operating free-air temperature range (unless otherwise noted).

PARAMETER	VSP2582	UNIT
Supply voltage V_{CC}, V_{DD}	+4.0	V
Ground voltage differences: AGND, DGND	±0.1	V
Digital input voltage	–0.3 to ($V_{DD} + 0.3$)	V
Analog input voltage	–0.3 to ($V_{CC} + 0.3$)	V
Input current (any pins except supplies)	±10	mA
Ambient temperature under bias	–25 to +85	°C
Storage temperature	–55 to +125	°C
Junction temperature	+150	°C
Package temperature (reflow, peak)	+250	°C

(1) Stresses beyond those listed under absolute maximum ratings may cause permanent damage to the device. Exposure to absolute-maximum-rated conditions for extended periods may affect device reliability. These are stress ratings only and functional operation of the device at these or any other conditions beyond those indicated under recommended operating conditions is not implied.

RECOMMENDED OPERATING CONDITIONS

Over operating free-air temperature range (unless otherwise noted).

	MIN	NOM	MAX	UNIT
Analog supply voltage V_{CC}	2.7	3.0	3.6	V
Digital supply voltage V_{DD}	2.7	3.0	3.6	V
Digital input logic family	CMOS			
Digital input clock frequency	MCK	12	36	MHz
	SCLK		20	MHz
Digital output load capacitance			20	pF
Operating free-air temperature, T_A	–25		+85	°C

ELECTRICAL CHARACTERISTICS

Over operating free-air temperature range (unless otherwise noted).

PARAMETER	TEST CONDITIONS	VSP2582RHN			UNIT
		MIN	TYP	MAX	
Resolution			12		Bits
Conversion rate				36	MHz
ANALOG INPUT (CCDIN)					
Input signal level for full-scale out	CDS gain = 0 dB, DPGA gain = 0 dB			1000	mV
Maximum input range	CDS gain = -3 dB, DPGA gain = 0 dB			1300	mV
Input capacitance			15		pF
Input limit		-0.3		3.3	V
TRANSFER CHARACTERISTICS					
Differential nonlinearity (DNL)	CDS gain = 0 dB, DPGA gain = 0 dB		±0.5		LSB
Integral nonlinearity (INL)	CDS gain = 0 dB, DPGA gain = 0 dB		±2		LSB
No missing codes			Ensured		
Step response settling time	Full-scale step input		1		Pixel
Overload recovery time	Step input from 1.8 V to 0 V		2		Pixels
Data latency			6		Clock
Signal-to-noise ratio ⁽¹⁾	Grounded input cap, PGA gain = 0 dB		78		dB
	Grounded input cap, CDS gain = +9 dB		71		dB
CCD offset correction range		-200		200	mV
INPUT CLAMP					
Clamp-on resistance			400		Ω
Clamp level			1.5		V
PROGRAMMABLE ANALOG FRONT GAIN (CDS)					
Minimum gain	Gain code = 111		-3		dB
Default gain	Gain code = 000		0		dB
Medium gain 1	Gain code = 001		3		dB
Medium gain 2	Gain code = 010		6		dB
Maximum gain	Gain code = 011		9		dB
Gain control error			0.5		dB
PROGRAMMABLE DIGITAL GAIN (DPGA)					
Programmable gain range		-6		26	dB
Gain step			0.03125		dB
OPTICAL BLACK CLAMP LOOP					
Control DAC resolution			10		Bits
Loop time constant	OB loop IDAC × 1, C _{COB} = 0.1 μF		40.7		μs
Optical black clamp level	Programmable range of clamp level	64		312	LSB
	OBCLP level at CODE = 0 1000		128		LSB
	OB level program step		8		LSB

(1) Input-referred; SNR = 20 log (full-scale voltage/rms noise).

ELECTRICAL CHARACTERISTICS (continued)

Over operating free-air temperature range (unless otherwise noted).

PARAMETER		TEST CONDITIONS	VSP2582RHN			UNIT
			MIN	TYP	MAX	
DIGITAL INPUTS						
Logic family			CMOS			
Input voltage	VT+	LOW to HIGH threshold voltage	1.7			V
	VT–	HIGH to LOW threshold voltage	1.0			V
Input current	I _{IH}	Logic HIGH, V _{IN} = +3 V	±20			μA
	I _{IL}	Logic LOW, V _{IN} = 0 V	±20			μA
Input capacitance			5			
Maximum input voltage			–0.3	V _{CC} + 0.3		V
DIGITAL OUTPUTS (DATA)						
Logic family			CMOS			
Logic coding			Straight Binary			
Output voltage	V _{OH}		2.4			V
	V _{OL}		0.4			V
Additional data output delay		Output data delay code = 00	0			ns
		Output data delay code = 01	2			ns
		Output data delay code = 10	4			ns
		Output data delay code = 11	6			ns
POWER SUPPLY						
Supply voltage	V _{CC}		2.7	3.0	3.6	V
	V _{DD}					
Power dissipation		at 3.0 V 36 MHz	85			mW
Standby mode power dissipation		Clocks (SHP/SHD/ADCCK) off mode (at 3.0 V)	1			mW
TEMPERATURE RANGE						
Operation temperature			–25	+85		°C
Thermal resistance	θ _{JA}		109			°C/W

PIN CONFIGURATION

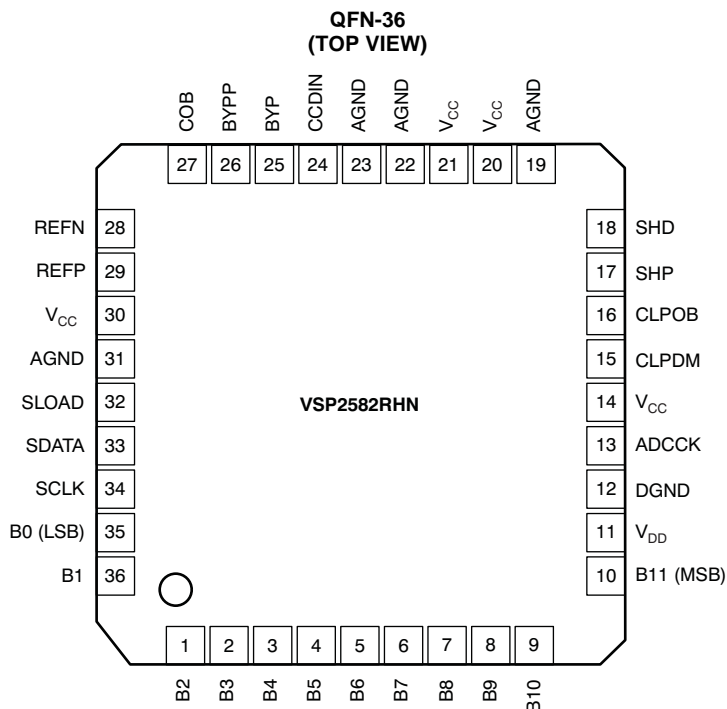
Table 1. TERMINAL FUNCTIONS

TERMINAL		TYPE ⁽¹⁾	DESCRIPTION
NAME	NO.		
B2	1	DO	Data out bit 2
B3	2	DO	Data out bit 3
B4	3	DO	Data out bit 4
B5	4	DO	Data out bit 5
B6	5	DO	Data out bit 6
B7	6	DO	Data out bit 7
B8	7	DO	Data out bit 8
B9	8	DO	Data out bit 9
B10	9	DO	Data out bit 10
B11	10	DO	Data out bit 11 (MSB)
V _{DD}	11	P	Digital power supply for data output
DGND	12	P	Digital ground for data output
ADCK	13	DI	Clock for digital output buffer
V _{CC}	14	P	Analog power supply
CLPDM	15	DI	CLPDM signal
CLPOB	16	DI	CLPOB signal
SHP	17	DI	Sampling clock for reference level of CCD signal
SHD	18	DI	Sampling clock for data level of CCD signal
AGND	19	P	Analog ground
V _{CC}	20	P	Analog power supply
V _{CC}	21	P	Analog power supply
AGND	22	P	Analog ground

(1) Designators in TYPE: P: Power Supply and Ground, DI: Digital Input, DO: Digital Output, AI: Analog Input, AO: Analog Output.

Table 1. TERMINAL FUNCTIONS (continued)

TERMINAL		TYPE ⁽¹⁾	DESCRIPTION
NAME	NO.		
AGND	23	P	Analog ground
CCDIN	24	AI	CCD signal input
BYP	25	AO	Internal reference bypass to ground by 0.1 μ F
BYPP	26	AO	Internal reference bypass to ground by 1000 pF
COB	27	AO	OB loop feed back capacitor
REFN	28	AO	Internal reference bypass to ground by 0.1 μ F
REFP	29	AO	Internal reference bypass to ground by 0.1 μ F
V _{CC}	30	P	Analog power supply
AGND	31	P	Analog ground
SLOAD	32	DI	Serial data latch signal
SDATA	33	DI	Serial data input
SCLK	34	DI	Serial data clock
B0	35	DO	Data out bit 0 (LSB)
B1	36	DO	Data out bit 1

FUNCTIONAL BLOCK DIAGRAM

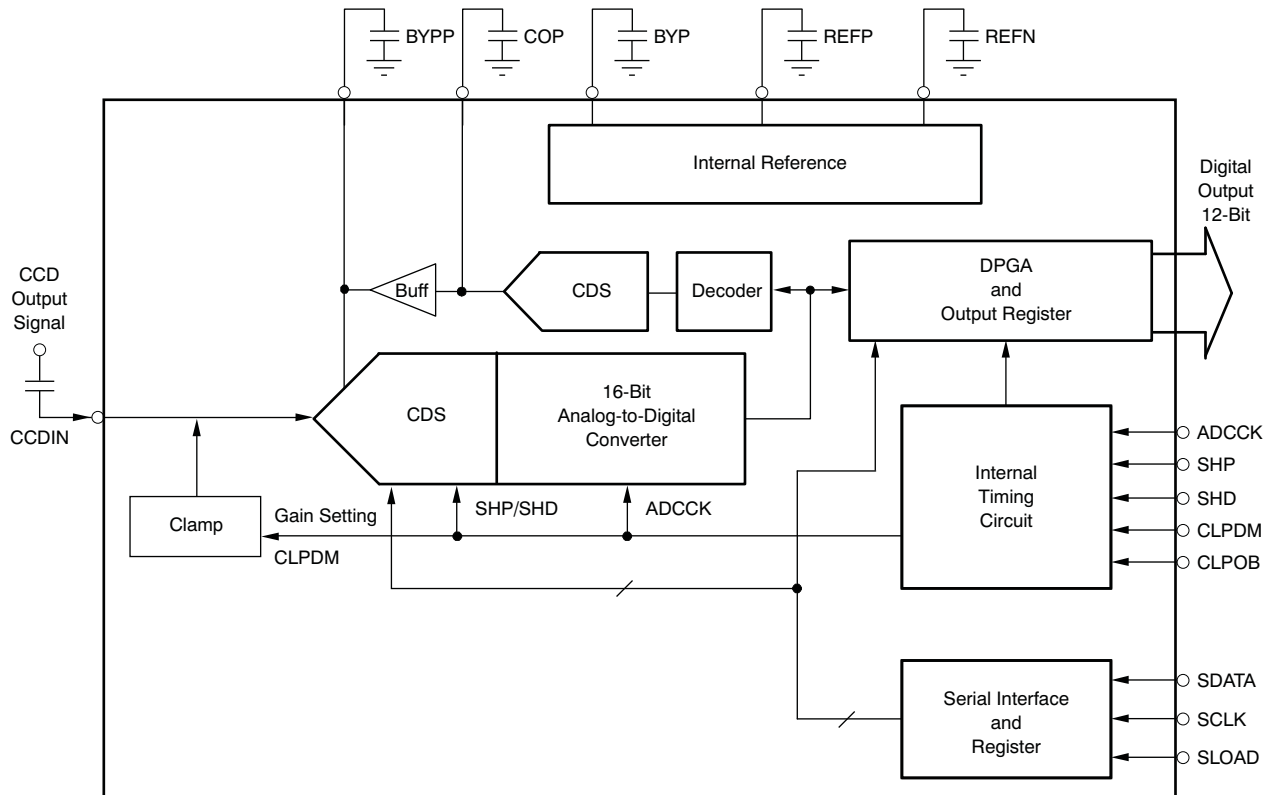

TIMING SPECIFICATIONS

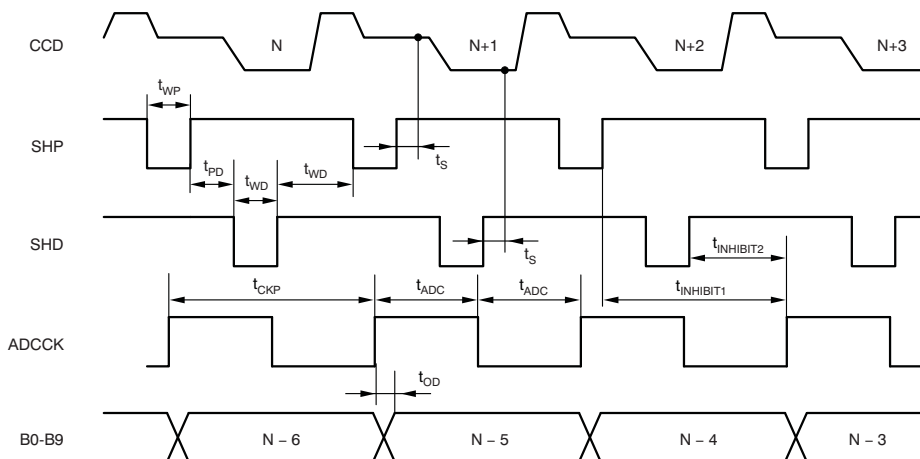

Figure 1. TG High-Speed Pulse Specifications

TIMING CHARACTERISTICS (36-MHz Operation)

SYMBOL	PARAMETER	MIN	TYP	MAX	UNIT
t _{CKP}	Clock period	27.7			ns
t _{ADC}	ADCK high or low level	6.5	13.8	21.2	ns
t _{WP}	SHP pulse width	5.9	6.9		ns
t _{WD}	SHD pulse width	5.9	6.9		ns
t _{PD}	SHP trailing edge to SHD leading edge	5.0	6.9		ns
t _{DP}	SHD trailing edge to SHP leading edge	5.2	6.9		ns
t _s	Sampling delay		3		ns
t _{INHIBIT1}	Inhibited clock period 1 (from rising edge of SHP to rising edge of ADCK)	-9		13	ns
t _{INHIBIT2}	Inhibited clock period 2 (from rising edge of SHD to rising edge of ADCK)	-8		-0	ns
t _{OD}	Output delay	0		5	ns
DL	Data latency		6		Clocks

TIMING CHARACTERISTICS (27-MHz Operation)

SYMBOL	PARAMETER	MIN	TYP	MAX	UNIT
t _{CKP}	Clock period		37		ns
t _{ADC}	ADCK high or low level	6.5	18.5	30.5	ns
t _{WP}	SHP pulse width	5.9	6.9		ns
t _{WD}	SHD pulse width	5.9	6.9		ns
t _{PD}	SHP trailing edge to SHD leading edge	5.9	6.9		ns
t _{DP}	SHD trailing edge to SHP leading edge	5.2	6.9		ns
t _s	Sampling delay		3		ns
t _{INHIBIT1}	Inhibited clock period 1 (from rising edge of SHP to rising edge of ADCK)	-9		13	ns
t _{INHIBIT2}	Inhibited clock period 2 (from rising edge of SHD to rising edge of ADCK)	-8		-0	ns
t _{OD}	Output delay	0		5	ns
DL	Data latency		6		Clocks

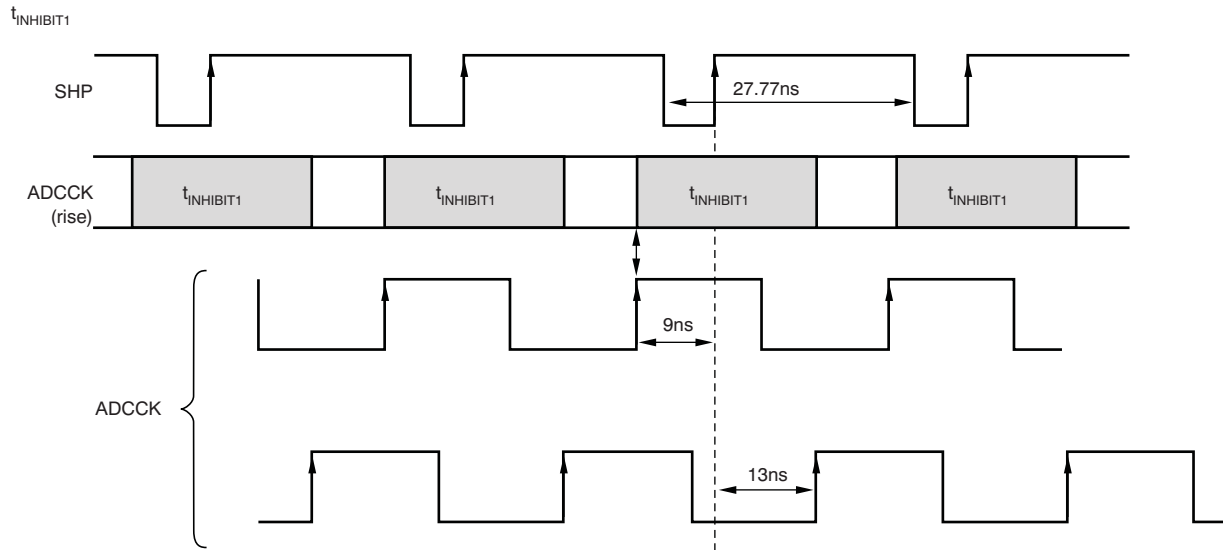

Note that in condition of OD (Output delay) = 00

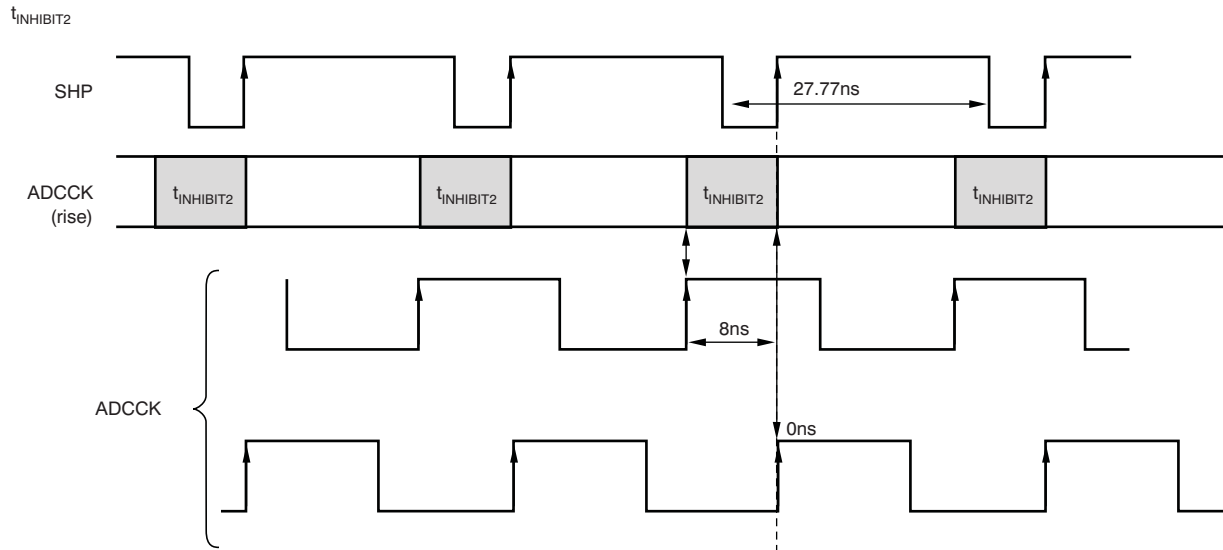

Figure 2. TG High-Speed Pulse Specifications (Detail of inhibit area)

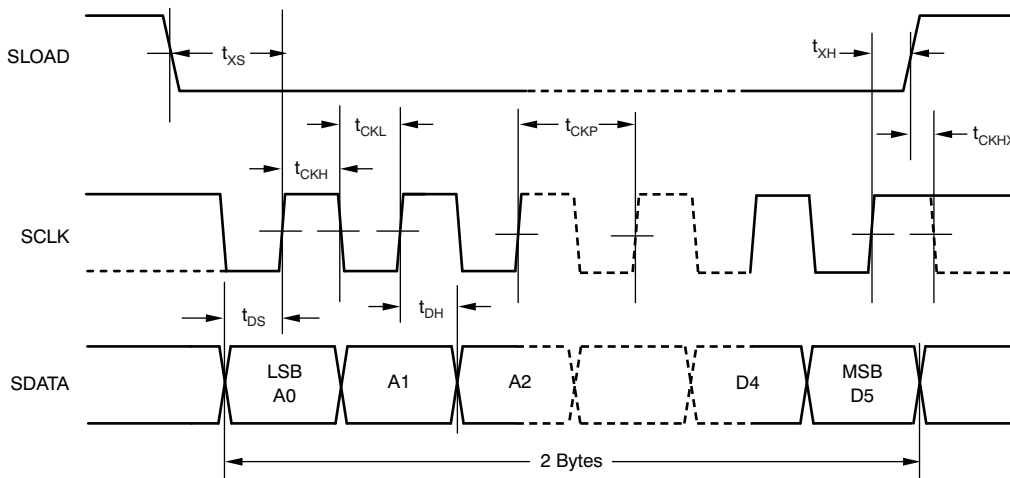

Figure 3. Serial Interface Timing Specification

SYMBOL	PARAMETER	MIN	TYP	MAX	UNIT
t_{CKP}	Clock period	50			ns
t_{CHH}	Clock high pulse width	25			ns
t_{CHL}	Clock low pulse width	25			ns
t_{DS}	Data setup time	15			ns
t_{DH}	Data hold time	15			ns
t_{xS}	SLOAD to SCLK setup time	20			ns
t_{xH}	SCLK to SLOAD hold time	20			ns
t_{CKHX}	SCLK hold time of final SCLK	0			ns

Input Clamp

The buffered CCD output is capacitively coupled to the VSP2582. The purpose of the input clamp is to restore the dc component of the input signal that was lost with ac coupling and establish the desired dc bias point for the CDS. Figure 5 also shows the block diagram of the input clamp. The input level is clamped to the internal reference voltage REFP (1.5 V) during the dummy pixel interval. More specifically, the clamping function becomes active when both CLPDM and SHP are active. Immediately after power ON, the clamp voltage of input capacitor has not charged. The VSP2582 provides a boost-up circuit for fast charging of the clamp voltage.

16-Bit A/D Converter

The VSP2582 includes a high-speed, 16-bit ADC. This ADC uses a fully differential pipelined architecture with correction. The ADC architecture correction is very advantageous to achieve better linearity for a smaller signal level because large linearity errors tend to occur at specific points in the full scale; linearity improves for a level of signal below that specific point. The ADC ensures 16-bit resolution across the entire full-scale range.

Optical Black (OB) Level Loop and OB Clamp Level

The VSP2582 has a built-in OB offset self calibration circuit (OB loop) that compensates the OB level by using Optical Black (OB) pixels output from the CCD image sensor. A block diagram of the OB loop and the OB clamp circuit is shown in Figure 6. The CCD offset is compensated by this calibration circuit while activating CLPOB during a period when OB pixels are output from the CCD.

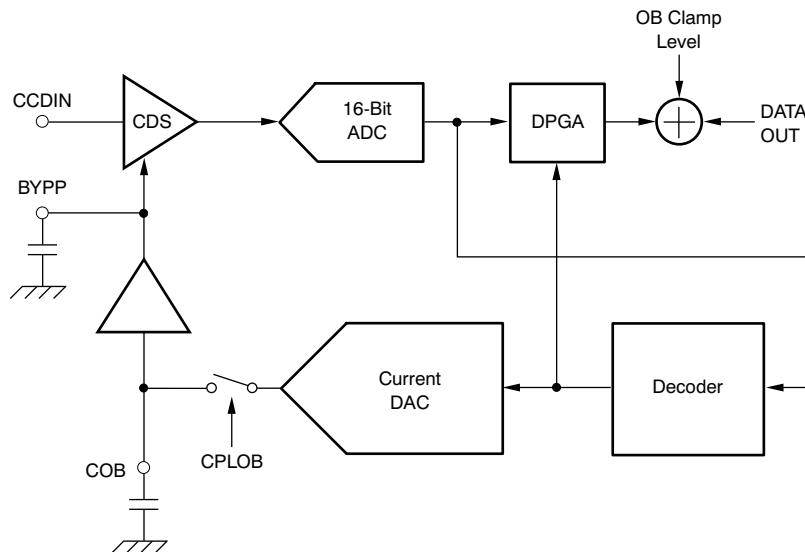

Figure 6. OB Loop and OB Level Clamp

At the CDS circuit, the CCD offset is compensated as a difference between the reference level and the data level of the OB pixel. The compensated signal levels are recognized as actual *OB levels*, and outputs are clamped to OB levels set by the serial interface. These OB levels are the base of black for the effective pixel period thereafter.

Since the DPGA is a gain stage outside the OB loop, OB levels are not affected even when the gain changes.

The converging time of the OB loop is determined based on the capacitor value connected to the COB terminal and the output from the current output data-to-analog converter (DAC) of the loop. The time constant can be obtained from following equation:

$$T = C / (16384 \times I_{\text{MIN}}) \quad (1)$$

Where C is the capacitor value connected to C_{OB}, and I_{MIN} is minimum current (0.15 μA) of the current DAC, which is a current equivalent to 1 LSB of the DAC output. When C = 0.1 μF, T will be 40.7 μs. The slew rate, SR, can be obtained from following equation:

$$SR = I_{\text{MAX}} / C \quad (2)$$

Where, C is the capacitor value connected to C_{OB}, and I_{MAX} is maximum current (153 μA) of the current DAC, with a current equivalent to 1023 LSB of the DAC output.

DAC output current multiplication is provided. This function increases the DAC output current through the serial interface at x2, x4 and x8. Increased DAC current shortens the time constant of the OB loop. This function is effective when a particular OB level changes significantly and requires fast loop setting.

On device power up, the COB capacitor voltages have not charged. For fast start up, a COB voltage boost-up circuit is provided.

The OB clamp level (digital output value) can be set from an external source through the serial interface by inputting a digital code to the OB clamp level register. The digital code to be input and the corresponding OB clamp level are shown in [Table 2](#).

Table 2. Input Code and OB Clamp Level to be Set

CODE	CLAMP LEVEL
	VSP2582 (12-BIT)
0 0000 (default)	64 LSB
0 0001	72 LSB
:	:
0 0110	112 LSB
0 0111	120 LSB
0 1000 (default)	128 LSB
0 1001	136 LSB
:	:
1 1110	304 LSB
1 1111	312 LSB

Programmable Gain

The VSP2582 has a wide programmable gain range of -9 dB to 35 dB. The desired gain is set as a combination of the CDS gain and Digital Programmable Gain Amplifier (DPGA). The CDS gain can be programmed over the range of -3 dB to 9 dB in 3-dB steps. Digital gain can be programmed from -6 dB to 26 dB by a 0.03125 dB step. Both gain settings are controlled through the serial interface. Digital Gain changes linearly in proportion to the setting code. Figure 7 shows the relationship of input code and digital gain.

The recommend usage of the CDS and digital gain combination is to first adjust the CDS gain as a primary image signal amplification; then, use digital gain as an adaptive gain control. The wide range of Digital gain covers the necessary gain range on most applications; if necessary, the CDS gain should be changed at periods that do not affect a picture such as a blanking period.

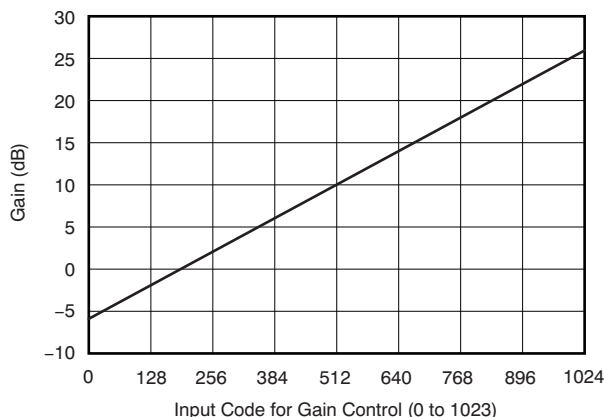

Figure 7. Setting Code vs. Digital Gain

Standby Mode and Power Trim Function

For the purposes of power saving, the VSP2582 can be put into a Standby Mode by the serial interface control when the device is not in use. In this mode, all functional blocks are disabled and the digital outputs all go to zero. Current consumption drops to approximately 2 mA. Only 10 ms are required to restore activity from the Standby Mode. Enter and resume from the Standby Mode through the serial interface.

The VSP2582 also provides a power trim function. This function trims the power of the CDS, ADC and Reference source. Through this trim function, power consumption can be reduced, although this reduction is not recommended at 36 -MHz operation because accuracy may degrade. This function is useful for low sampling rate operation.

Timings

The CDS and the ADC are operated by SHP and SHD; the respective derivative timing clocks are generated by the on-chip timing generator. The Output Register and Decoder are operated by ADCCK. The digital output data are synchronized with ADCCK. The timing relationship between the CCD signal, SHP, SHD, ADCCK, and the output data is shown in Figure 1. CLPOB activates the black level clamp loop during the OB pixel interval and CLPDM activates the input clamping during the dummy pixel interval. In the Standby mode, all of ADCCK, SHP, SHD, CLPOB and CLPDM data are internally masked and pulled HIGH.

As explained in the Input Clamp and Optical Black Level (OB) Loop and OB Clamp Level sections, CLPOB is used to control the OB loop which compensates CCD offset automatically. CLPDM is used to charge the input clamp voltage to capacitor C_{IN} which is connected to CCDIN. For proper operation, both CLPOB and CLPDM should be activated in the following manner.

The CCD has several dummy and Optical Black pixels per line. The placement of these pixels depends on the CCD manufacturer, but are usually at the beginning and end of the line with the imaging pixels in between. During the time the dummy pixels are being read from the CCD, it is recommended to activate CLPDM. During the time the Optical Black pixels are being read, it is recommended to activate CLPOB. If there are only a few dummy pixels, then the leakage from capacitor C_{IN} may become excessive. In this case, extend the active period of CLPDM into the Optical Black pixels. Do not activate CLPDM and CLPOB at the same time; each of these pixel types must be used only as either a dummy pixel (CLPDM active) or an Optical Black pixel (CLPOB active). Typically for CLPOB about 20 pixels per line are sufficient and for CLPDM about 10-20 pixels are sufficient. Figure 8 shows typical timing for CLPDM and CLPOB for a line of CCD readout.

Under default conditions, SHP and SHD are active on the rising edge; CLPOB and CLPDM are active low. The active state of each signal can be selected by register settings.

SHP, SHD, CLPOB, and CLPDM are active at low periods or upon a rising edge at the default setting of the serial interface; each active polarity can be selected by a register setting.

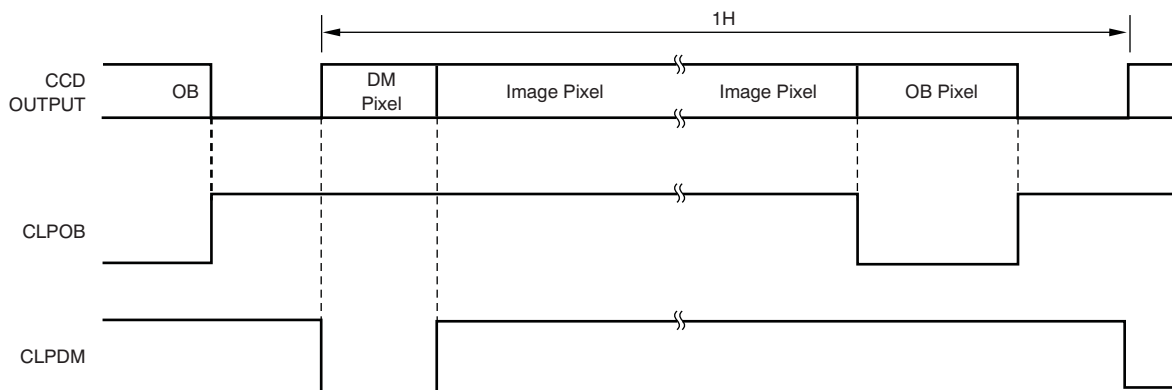

Figure 8. Timing for CLPOB and CLPDM

Voltage Reference

All reference voltages and bias currents used on the device are created from an internal bandgap circuitry. The VSP2582 has symmetrical independent voltage reference for each channel.

Both channels of CDS and the ADC use three primary reference voltages. REFP (1.5 V) and REFN (1.0 V) are individual references. REFP and REFN are buffered on-chip. The ADC full-scale range is determined by twice the difference voltage between REFP and REFN.

REFP and REFN should be heavily decoupled with appropriate capacitors.

Hot Pixel Rejection

Sometimes an OB pixel output signal from the CCD includes unusual signal levels that are caused by pixel defection. If this level reaches full-scale level, it may affect OB level stability. The VSP2582 is able to reject an unusually large pixel level (hot pixel) at the OB pixel. This function may contribute to CCD yield improvement which is caused by OB pixel failure.

The rejection level for hot pixels is able to programmed through the serial interface. When the OB pixel level exceeds that level, the VSP2582 omits it and uses the previous pixel level for OB level calculation.

SERIAL INTERFACE

All functions and settings of the VSP2582 are controlled through the serial interface. The VSP2582 serial interface is composed of three signals: SDATA, SCLK, and SLOAD. SDATA data are sequentially stored to shift into the register at a rising edge or SCLK, and shift register data are stored in a parallel latch at an SLOAD rising edge. Before a write operation, SLOAD must go LOW and stay low during the write process. (Refer serial interface timing description)

The serial interface command is composed of a 10-bit address and 6 bits of data. The fundamental write operation is done in a 2-byte write mode. In this mode, one serial interface command is sent by one combination of address and data bits. The 10 address bits should be sent LSB first, followed by 6 bits of data also sent LSB first. The 6-bit command data are stored to the respective register by the 10 address bits at the rising edge of SLOAD. The stored serial command data takes effect immediately upon the rising edge of SLOAD.

The VSP2582 also supports a continuous write mode as below. When the input serial data are longer than 2 bytes (16 bits), the following data stream is automatically recognized as the data of next address. In this mode, 6 bits of serial command data are stored to the respective register immediately when those data are fetched. Address and data should be sent LSB first, the same as the 2-byte writing mode. If a data bit is not complete, or if there are 6 bits at the end part of this data stream, non fill-up data bits are ignored.

The setting for the serial interface register is described in the [Serial Interface Register Description](#). Figure 9 shows the continuous writing mode.

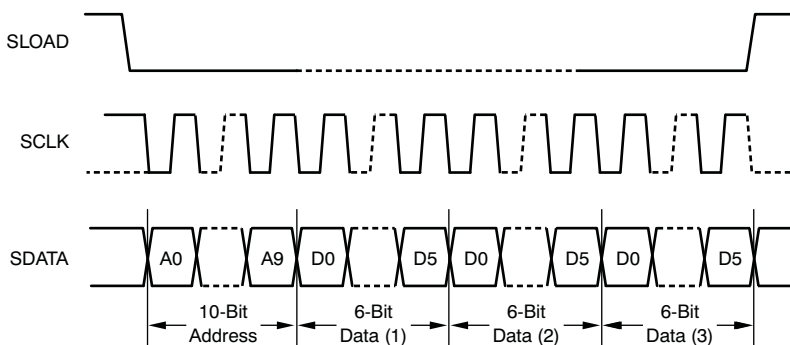

Figure 9. Continuous Writing Mode

Serial Interface Register Description

Table 3 shows the serial interface command data format. Descriptions of each register follow.

Table 3. Serial Interface Command Data Format

REGISTERS	ADDRESS										DATA					
	MSB									LSB	MSB					LSB
	A9	A8	A7	A6	A5	A4	A3	A2	A1	A0	D5	D4	D3	D2	D1	D0
Clk-Pol-ctrl	0	0	0	0	0	0	0	0	0	0	D5	D4	D3	0	0	0
AFE-ctrl(1)	0	0	0	0	0	0	0	0	0	1	0	0	D3	0	0	D0
AFE-ctrl(2)	0	0	0	0	0	0	0	0	1	0	0	D4	0	0	D1	D0
S-delay	0	0	0	0	0	0	0	0	1	1	0	0	0	0	D1	D0
Clamp	0	0	0	0	0	0	0	1	0	0	0	D4	D3	D2	D1	D0
Hot-pixel	0	0	0	0	0	0	0	1	0	1	D5	D4	D3	D2	D1	D0
D-PGA_L	0	0	0	0	0	0	0	1	1	0	D5	D4	D3	D2	D1	D0
D-PGA_U	0	0	0	0	0	0	0	1	1	1	0	0	D3	D2	D1	D0
A-PGA	0	0	0	0	0	0	1	0	0	0	0	0	0	D2	D1	D0
Power	0	0	0	0	0	0	1	0	0	1	0	D4	D3	D2	D1	D0
Reserved	Other address is reserved.										Do not use					

Clk-Pol-ctrl Register (Address: h000)

Clk-Pol-ctrl selects the active polarity of CLPDM, CLPOB, and SHP/SHD.

DATA BIT	NAME	DESCRIPTION		DEFAULT
D3	CLPDM Polarity	0 : Active Low	1 : Active High	0
D4	CLPOB Polarity	0 : Active Low	1 : Active High	0
D5	SHP/SHD Polarity	0 : Active Low	1 : Active High	0

AFE-ctrl(1) Register (Address: h001)

DATA BIT	NAME	DESCRIPTION		DEFAULT
D0	Standby	0: Normal operation	1: standby	0
D3	Test enable	0: disable	1: enable	0

AFE-ctrl(2) Register (Address: h002)

AFE-ctrl(2) register controls the following data output settings.

DATA BIT	NAME	DESCRIPTION		DEFAULT
D[1:0]	Data output delay	00: 0 ns, 01: 2 ns, 10: 4 ns, 11: 6 ns		0
D4	Output enable	0: enable	1: Hi-Z	0

S-delay Register (Address: h003)

S-delay register controls SHD sampling start time from the rising edge or SHP.

DATA BIT	NAME	DESCRIPTION	DEFAULT
D[1:0]	Sampling delay for SHD	00: 0 ns, 01: 2 ns (10, 11 are not allowed)	0

Clamp Register (Address: h004)

D4	D3	D2	D1	D0	CLAMP LEVEL (VSP2582)
0	0	0	0	0	64 LSB
0	0	0	0	1	72 LSB
:					:
0	0	1	1	1	120 LSB
0	1	0	0	0	128 LSB (default)
0	1	0	0	1	136 LSB
:					:
1	1	1	1	0	304 LSB
1	1	1	1	1	312 LSB

Hot-pixel Register (Address: h005)

DATA BIT	NAME	DESCRIPTION	DEFAULT
D[4:0]	Hot pixel rejection level	Hot pixel rejection level is given following equation. Gain (dB) = (D-PGA • 0.03125) – 6 Where: R _L is level difference from OB level.	11111
D5	Hot pixel rejection disable	0: disable	1: enable

D-PGA Register (Address: h006 and h007)

D-PGA_U	D-PGA_L	ANALOG GAIN	DEFAULT
D[3:0]	D[5:0]	Digital PGA gain is given following equation. Gain (dB) = (D-PGA • 0.03125) – 6 Where: D-PGA is decimal value of 10-bit data which is combined D-PGA_U and D-PGA_L. D-PGA_U is MSB side of D-PGA.	D-PGA = 00 1100 000 = 0 dB

A-PGA Register (Address: h008)

CDS Gain control

D2	D1	D0	ANALOG GAIN
0	0	0	0 dB (default)
0	0	1	3 dB
0	1	0	6 dB
0	1	1	9 dB
1	1	1	-3 dB

NOTE:

Other values of D[2:0] are not applicable.

Power Register (Address: h009)

DATA BIT	NAME	DESCRIPTION	DEFAULT
D[1:0]	OB loop IDAC output current	00: x1, 01: x2, 10: x4, 11: x8	00
D[2]	CDS Power Trim	0: Normal CDS Power, 1: Reduce CDS Power	0
D[3]	ADC Power Trim	0: Normal ADC Power, 1: Reduce ADC Power	0
D[4]	Ref Power Trim	0: Normal Ref Power, 1: Reduce Ref Power	0

POWER SUPPLY, GROUNDING AND DEVICE DECOUPLING RECOMMENDATIONS

The VSP2582 incorporates a high-precision, high-speed analog-to-digital converter and analog circuitry that is vulnerable to any extraneous noise from the rails or elsewhere. For this reason, although the VSP2582 has multiple supply pins, it should be treated as an analog component; all supply pins except for V_{DD} should be powered by only the analog supply of the system. This configuration ensures the most consistent results, because digital power lines often carry high levels of wideband noise that would otherwise be coupled into the device and degrade achievable performance.

Proper grounding, short lead length, and proper use of ground planes are also very important for high-frequency designs. Multilayer printed circuit boards (PCBs) are recommended for best performance because they offer distinct advantages such as minimizing ground impedance, separation of signal layers by ground layers, etc. It is highly recommended that the analog and digital ground pins of the VSP2582 be joined together at the IC and be connected only to the analog ground of the system. The driver stage of the digital outputs (B(9:0)) is supplied through a dedicated supply pin (V_{DD}) and should be separated from the other supply pins completely, or at least with a ferrite bead. It is also recommended to keep the capacitive loading on the output data lines as low as possible (typically less than 15 pF). Larger capacitive loads demand higher charging current as a result of surges that can feed back into the analog portion of the VSP2582 and affect performance. If possible, external buffers or latches should be used that provide the added benefit of isolating the VSP2582 from any digital noise activities on the data lines. In addition, resistors in series with each data line may help minimize surge current.

Because of the high operating speed, the converter also generates high-frequency current transients and noises that are fed back into the supply and reference lines. This interference requires the supply and reference pins to be sufficiently bypassed. In most cases, a 0.1- μ F ceramic-chip capacitor is adequate to decouple the reference pins. Supply pins should be decoupled to the ground plane with a parallel combination of tantalum (1 μ F to 22 μ F) and ceramic (0.1 μ F) capacitors. The effectiveness of the decoupling largely depends on the proximity to the individual pin. V_{DD} should be decoupled to the proximity of DGND. Special attention must be paid to the bypassing of COB and BYPP because these capacitor values determine the important analog performance of the device. Although the recommend capacitor values for COB and BYPP are 0.1 μ F and 1000 pF, respectively, it is better to adjust the capacitor for BYPP at the case.

PACKAGING INFORMATION

Orderable Device	Status ⁽¹⁾	Package Type	Package Drawing	Pins	Package Qty	Eco Plan ⁽²⁾	Lead/Ball Finish	MSL Peak Temp ⁽³⁾
VSP2582RHN	ACTIVE	QFN	RHN	36	250	Green (RoHS & no Sb/Br)	CU NIPDAU	Level-1-260C-UNLIM
VSP2582RHNG4	ACTIVE	QFN	RHN	36	250	Green (RoHS & no Sb/Br)	CU NIPDAU	Level-1-260C-UNLIM
VSP2582RHNR	ACTIVE	QFN	RHN	36	2000	Green (RoHS & no Sb/Br)	CU NIPDAU	Level-1-260C-UNLIM
VSP2582RHNRG4	ACTIVE	QFN	RHN	36	2000	Green (RoHS & no Sb/Br)	CU NIPDAU	Level-1-260C-UNLIM

⁽¹⁾ The marketing status values are defined as follows:

ACTIVE: Product device recommended for new designs.

LIFEBUY: TI has announced that the device will be discontinued, and a lifetime-buy period is in effect.

NRND: Not recommended for new designs. Device is in production to support existing customers, but TI does not recommend using this part in a new design.

PREVIEW: Device has been announced but is not in production. Samples may or may not be available.

OBSOLETE: TI has discontinued the production of the device.

⁽²⁾ Eco Plan - The planned eco-friendly classification: Pb-Free (RoHS), Pb-Free (RoHS Exempt), or Green (RoHS & no Sb/Br) - please check <http://www.ti.com/productcontent> for the latest availability information and additional product content details.

TBD: The Pb-Free/Green conversion plan has not been defined.

Pb-Free (RoHS): TI's terms "Lead-Free" or "Pb-Free" mean semiconductor products that are compatible with the current RoHS requirements for all 6 substances, including the requirement that lead not exceed 0.1% by weight in homogeneous materials. Where designed to be soldered at high temperatures, TI Pb-Free products are suitable for use in specified lead-free processes.

Pb-Free (RoHS Exempt): This component has a RoHS exemption for either 1) lead-based flip-chip solder bumps used between the die and package, or 2) lead-based die adhesive used between the die and leadframe. The component is otherwise considered Pb-Free (RoHS compatible) as defined above.

Green (RoHS & no Sb/Br): TI defines "Green" to mean Pb-Free (RoHS compatible), and free of Bromine (Br) and Antimony (Sb) based flame retardants (Br or Sb do not exceed 0.1% by weight in homogeneous material)

⁽³⁾ MSL, Peak Temp. -- The Moisture Sensitivity Level rating according to the JEDEC industry standard classifications, and peak solder temperature.

Important Information and Disclaimer:The information provided on this page represents TI's knowledge and belief as of the date that it is provided. TI bases its knowledge and belief on information provided by third parties, and makes no representation or warranty as to the accuracy of such information. Efforts are underway to better integrate information from third parties. TI has taken and continues to take reasonable steps to provide representative and accurate information but may not have conducted destructive testing or chemical analysis on incoming materials and chemicals. TI and TI suppliers consider certain information to be proprietary, and thus CAS numbers and other limited information may not be available for release.

In no event shall TI's liability arising out of such information exceed the total purchase price of the TI part(s) at issue in this document sold by TI to Customer on an annual basis.

TAPE AND REEL INFORMATION

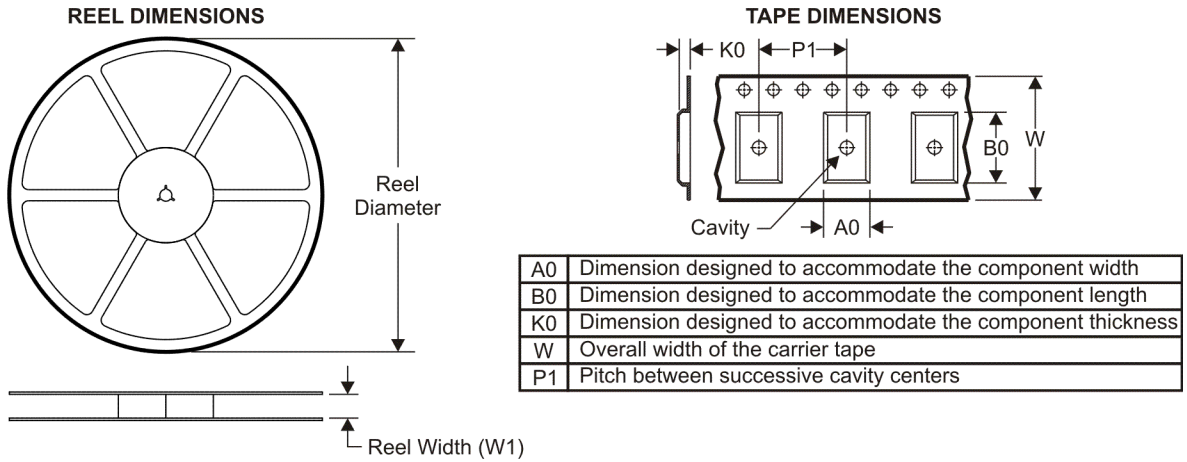

QUADRANT ASSIGNMENTS FOR PIN 1 ORIENTATION IN TAPE



*All dimensions are nominal

Device	Package Type	Package Drawing	Pins	SPQ	Reel Diameter (mm)	Reel Width W1 (mm)	A0 (mm)	B0 (mm)	K0 (mm)	P1 (mm)	W (mm)	Pin1 Quadrant
VSP2582RHNR	QFN	RHN	36	2000	330.0	13.4	6.6	6.6	1.15	8.0	12.0	Q1

TAPE AND REEL BOX DIMENSIONS



*All dimensions are nominal

Device	Package Type	Package Drawing	Pins	SPQ	Length (mm)	Width (mm)	Height (mm)
VSP2582RHNR	QFN	RHN	36	2000	346.0	346.0	29.0

IMPORTANT NOTICE

Texas Instruments Incorporated and its subsidiaries (TI) reserve the right to make corrections, modifications, enhancements, improvements, and other changes to its products and services at any time and to discontinue any product or service without notice. Customers should obtain the latest relevant information before placing orders and should verify that such information is current and complete. All products are sold subject to TI's terms and conditions of sale supplied at the time of order acknowledgment.

TI warrants performance of its hardware products to the specifications applicable at the time of sale in accordance with TI's standard warranty. Testing and other quality control techniques are used to the extent TI deems necessary to support this warranty. Except where mandated by government requirements, testing of all parameters of each product is not necessarily performed.

TI assumes no liability for applications assistance or customer product design. Customers are responsible for their products and applications using TI components. To minimize the risks associated with customer products and applications, customers should provide adequate design and operating safeguards.

TI does not warrant or represent that any license, either express or implied, is granted under any TI patent right, copyright, mask work right, or other TI intellectual property right relating to any combination, machine, or process in which TI products or services are used. Information published by TI regarding third-party products or services does not constitute a license from TI to use such products or services or a warranty or endorsement thereof. Use of such information may require a license from a third party under the patents or other intellectual property of the third party, or a license from TI under the patents or other intellectual property of TI.

Reproduction of TI information in TI data books or data sheets is permissible only if reproduction is without alteration and is accompanied by all associated warranties, conditions, limitations, and notices. Reproduction of this information with alteration is an unfair and deceptive business practice. TI is not responsible or liable for such altered documentation. Information of third parties may be subject to additional restrictions.

Resale of TI products or services with statements different from or beyond the parameters stated by TI for that product or service voids all express and any implied warranties for the associated TI product or service and is an unfair and deceptive business practice. TI is not responsible or liable for any such statements.

TI products are not authorized for use in safety-critical applications (such as life support) where a failure of the TI product would reasonably be expected to cause severe personal injury or death, unless officers of the parties have executed an agreement specifically governing such use. Buyers represent that they have all necessary expertise in the safety and regulatory ramifications of their applications, and acknowledge and agree that they are solely responsible for all legal, regulatory and safety-related requirements concerning their products and any use of TI products in such safety-critical applications, notwithstanding any applications-related information or support that may be provided by TI. Further, Buyers must fully indemnify TI and its representatives against any damages arising out of the use of TI products in such safety-critical applications.

TI products are neither designed nor intended for use in military/aerospace applications or environments unless the TI products are specifically designated by TI as military-grade or "enhanced plastic." Only products designated by TI as military-grade meet military specifications. Buyers acknowledge and agree that any such use of TI products which TI has not designated as military-grade is solely at the Buyer's risk, and that they are solely responsible for compliance with all legal and regulatory requirements in connection with such use.

TI products are neither designed nor intended for use in automotive applications or environments unless the specific TI products are designated by TI as compliant with ISO/TS 16949 requirements. Buyers acknowledge and agree that, if they use any non-designated products in automotive applications, TI will not be responsible for any failure to meet such requirements.

Following are URLs where you can obtain information on other Texas Instruments products and application solutions:

Products

Amplifiers	amplifier.ti.com
Data Converters	dataconverter.ti.com
DSP	dsp.ti.com
Clocks and Timers	www.ti.com/clocks
Interface	interface.ti.com
Logic	logic.ti.com
Power Mgmt	power.ti.com
Microcontrollers	microcontroller.ti.com
RFID	www.ti-rfid.com
RF/IF and ZigBee® Solutions	www.ti.com/lprf

Applications

Audio	www.ti.com/audio
Automotive	www.ti.com/automotive
Broadband	www.ti.com/broadband
Digital Control	www.ti.com/digitalcontrol
Medical	www.ti.com/medical
Military	www.ti.com/military
Optical Networking	www.ti.com/opticalnetwork
Security	www.ti.com/security
Telephony	www.ti.com/telephony
Video & Imaging	www.ti.com/video
Wireless	www.ti.com/wireless

Mailing Address: Texas Instruments, Post Office Box 655303, Dallas, Texas 75265
Copyright © 2008, Texas Instruments Incorporated